

The

Guide

to

Curing

Chimney

Problems

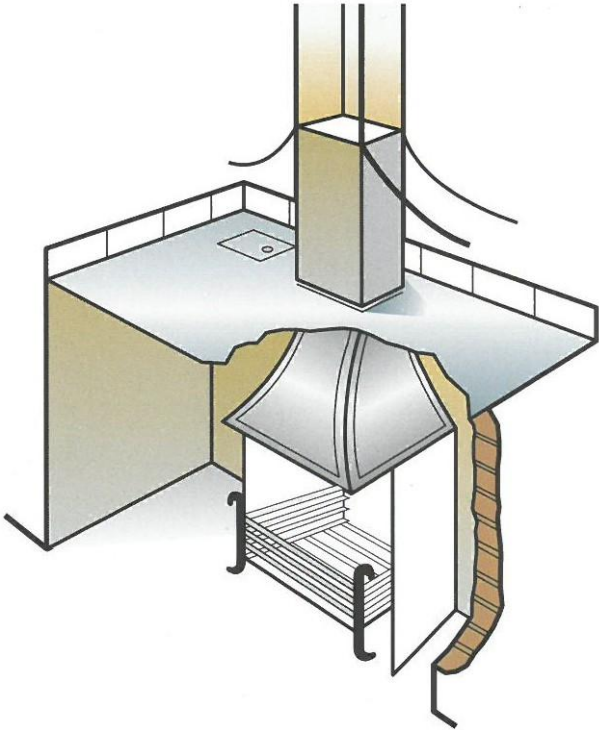

SOLID FUEL ASSOCIATION

Introduction

A MODERN solid fuel appliance, like any other item of household equipment, gives most satisfaction when it is properly selected and correctly fixed. Then it is unlikely to give any trouble at all. There are occasions, however, particularly where the older types of inset open fires are still used, when the problem of the smoky fire presents itself.

Smoke problems and lack of chimney draught are caused by poor chimney design and construction, insufficient sweeping of the chimney and any internal flueways in the appliance or unfavourable site conditions.

The purpose of this booklet is to describe the likely causes and to explain what can be done about them. It is, however, almost inevitable that a booklet concerned with faults and remedies might give an erroneous impression of the extent and severity of the troubles it describes. To be reasonably comprehensive, however, it is desirable to cover the rare cases as well as the more simple ones, and the fact that so many possible causes of smokiness of fires have been dealt with must not be taken to mean that all the faults described are either frequently met or necessarily difficult to remedy.

If after reading this booklet there is any doubt about how to make your chimney function properly, contact the Solid Fuel Association on 01773 835400 for free advice.

C O N T E N T S

| | |
|--|----|
| INTRODUCTION | 2 |
| HOW A FLUE FUNCTIONS | 3 |
| DIAGNOSING PROBLEMS | 3 |
| INSUFFICIENT DRAUGHT | 4 |
| Air starvation - Throat-over-fire too large, or badly formed - Fireplace opening too large - Fireplace (surround) opening too high - Flue offset too low, too abrupt, too long - Partial blockage or constriction of flue - Unsuitable size of flue - Bad fixing of liners - Unsuitable chimney pot Partially blocked chimney pot - Baffling of flue gases - Air leaks | |
| NO UP-DRAUGHT AT ALL | 11 |
| Blockage in Flue - Cold flue | |
| CHIMNEY TERMINATES IN A HIGH-PRESSURE REGION | 12 |
| Chimney top being in a high pressure region | |
| DOWN-DRAUGHT AND DIFFICULT SITE CONDITIONS | 13 |
| Down-draught due to room inlets (doors, windows, ventilators) being in a low pressure region - Down-draught due to wind currents | |
| TOO MUCH DRAUGHT | 14 |
| CONDENSATION | 14 |
| SMOKE TEST METHOD | 15 |
| Suggested method for checking the soundness of a chimney by smoke test | |

How a

Flue

Functions

Diagnosing

Problems

The up-draught or 'pull' in a flue results from a combination of the height of the flue and the difference in temperature between the flue gases and the outside air. Very simply the column of hot gases in a flue is lighter in weight than an equivalent column of cold air outside, so the pressure inside a warm flue is less than the air pressure outside. It is this quite small difference in pressure that creates up-draught. The warmer and taller a flue the better the draught and less risk of condensation.

Large voids or pockets, rough surfaces and sharp bends or steep angles in a flue are resistances to the flow of flue gases and reduce the draught, for this reason they should be eliminated as far as possible, particularly in the case of open fires.

Air leakage into a flue has the effect of cooling the flue gases and therefore reducing draught.

In certain circumstances it may be desirable to reduce an excessive draught by introducing 'dilution' air into a flue, but this should only be done in a controlled way, not by allowing accidental air leakage.

Wind at the top of a chimney may have a positive or negative effect on draught, depending on the surroundings and the position of the chimney top in relation to the roof.

Faulty chimney draught may show itself either in a sluggish fire and general poor performance of the appliance, but may cause the actual escape of smoke and fumes into the room. A fire will burn sluggishly when the draught is too little to supply sufficient air to the fire but there is just enough chimney 'pull' to carry away the smoke; this usually occurs with independent boilers, cookers and roomheaters. On the other hand, the opposite problem of too much up-draught sometimes arises with closed appliances, such as independent boilers. This makes it difficult to control the burning rate with the normal combustion air control, particularly in windy weather.

When smoke or fumes actually escape into the room, the more usual reasons are:

- A Insufficient draught to carry away all the smoke.
- B No up-draught.
- C Chimney terminates in high-pressure zone.
- D Down-draught and difficult site conditions.

The smokiness can be due to a variety of causes, several of which could operate together; it is therefore not always a simple matter to diagnose the cause of the problem, nor is there any universally successful treatment or 'cure-all' - each individual case has to be treated on its own symptoms.

To be able to cure smokiness, it is first of all necessary to know why it occurs, and because of the various possible reasons, not all of which are immediately obvious, it is advisable to set about the job in an orderly way and to follow a set sequence of operations.

The first step is to read through this booklet, as sometimes a fault can be recognised immediately from a description of it and the trouble corrected without the need for a lengthy investigation. If, however, the cause of trouble is not obvious, the next step is to check the symptoms, the more common of which are:

Symptom A

Some smoke or fumes, but not all, escape into the room without any sign of being blown back by the wind. Smokiness is constant and usually occurs regardless of weather conditions, although the wind may have some effect in either worsening or improving matters. This usually means insufficient draught.

Symptom A

Insufficient

Draught

Symptom B

No up-draught at all, but no sign of blowing back. Usually constant and unaffected by wind conditions.

Symptom C

Intermittent blowing back with the wind in a certain quarter. The degree of smokiness will vary with wind strength.

Symptom D

With the wind in a certain quarter the draught stops or reverses and causes smoke emission. The draught returns when the wind ceases or changes direction.

Finally, one or more easy tests should be carried out, the results of which will usually indicate the cause of smokiness. It is not unknown for two or perhaps three different tests to give positive results; this may mean that there are several causes operating together. For example, a simple case of down-draught could be complicated by air starvation, or a badly formed throat could be associated with a partially blocked flue.

For quick reference, the possible causes of smokiness, methods of testing and suggested remedies are listed as A.1, A.2, B.1, C.1, etc., to cross-check with the main symptoms outlined above.

Too much chimney draught and condensation in a flue are dealt with under separate headings at the end of this booklet.

A.1. 'AIR STARVATION'

All solid fuel burning appliances need a flow of air into the room, some, particularly the open fire, need more air than others. In addition to the air required to burn the fuel, a much larger quantity flows over the fire, through the appliance or fireplace opening, and up the flue.

A closed appliance may need only 15 to 25 cubic metres of air per hour, whereas an inset open fire with a large fire opening and large 'throat' induces the flow of an extra 260 cubic metres (9000 cubic feet) or more per hour. If the required amount is not available, the air speed through the fireplace opening is reduced and may fail to carry all the smoke into the flue. Sufficient air to carry away the smoke cannot enter a room that is too well draught-proofed, or which has a solid concrete floor and well-fitting doors and windows see Fig.1.

TEST *Open a door or window, preferably when there is no wind to complicate matters. If smoking into the room ceases, the trouble is usually due to air starvation.*

REMEDY It is necessary to allow more air into the room, but in a way that avoids unpleasant draughts, this is often difficult. The first step should be to see if it is possible to reduce the volume of air flowing up the flue so the 'demand' for air is less. An inspection of the throat over the fire may reveal a large throat without any attempt at streamlining and an even larger void beyond and at the sides - see Fig.2a and 2b.

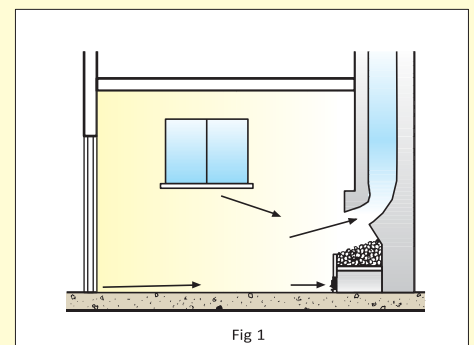

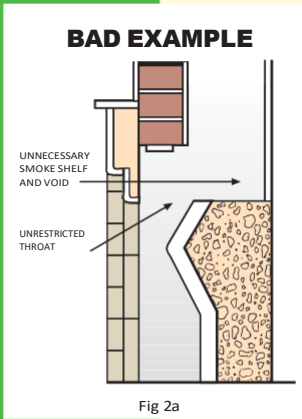

Fig 2a

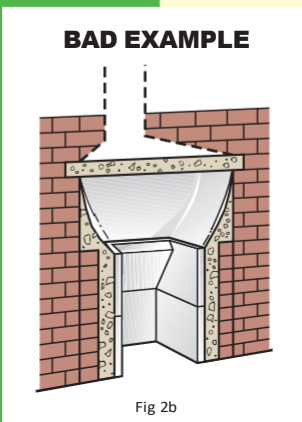

Fig 2b

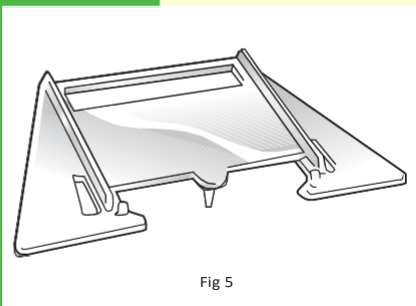

Fig 5

The void should be filled in and the throat reduced so that there is a smooth, streamlined entry into the flue as shown in Fig.3a and 3b. If the throat opening can be made adjustable for size it will be better still, as then the minimum amount of opening can be found to suit the 'pull' of the flue when the chimney is warm, and yet allow the full opening for relighting the fire when the chimney is cold.

There are proprietary throat restrictors available which can be easily fitted. When these units are used it is possible to reduce air flow from the room in to the flue. This reduction, in conjunction with perhaps the removal of some over-zealous draught proofing around doors and windows,

may cure the less serious cases. Bad cases often require further treatment. As well as helping air starvation a throat restrictor is an excellent means of making a room more comfortable by reducing the air induced up the flue and so reducing excessive ventilation.

Additional ventilation for the room to satisfy the 'demand' caused by the pull of the flue can usually be provided without resulting in unpleasant cold draughts. Fitting a louvred grille or adjustable ventilator over the door to the room will draw air from the hall which is less cold than the outside air.

With a suspended floor (boards on joists), extra air inlets fixed in the floorboards adjacent to the hearth may sometimes help, but the results are frequently disappointing unless they are large enough

Where there are solid floors, air inlets are limited to the walls.

The most effective way of dealing with the problem of air starvation is to install a modern roomheater in place of the open fire, this drastically reduces the volume of air from the room flowing up the flue and increases heating efficiency.

A.2. THROAT-OVER-FIRE TOO LARGE, OR BADLY FORMED

The velocity of the gases at this point should be high, so that the action is similar to that of a vacuum cleaner nozzle. The smooth, swift movement of the smoke and gases may be impeded by the irregular shape of the throat and the large void above, at the sides or behind it. Fig.2a and 2b show a bad throat construction and voids that are all too common. Fig.3a and 3b show the proper reconstruction of this throat and streamlining of the 'gather' up to the point where the flue itself begins.

TEST *Very often the turbulence and eddying of smoke can be clearly seen. A simple test makes use of a piece of cardboard or thin sheet metal cut and bent so that it can easily be wedged across the front of the throat in a similar position and shape to the streamlined lintel shown in Fig.3a).*

REMEDY Reconstruct the throat as shown, or, perhaps better still, fill in and streamline the voids and fix an adjustable throat restrictor of the type shown in Fig.5. Filling in, which should be carried up as near to the flue as possible, is usually done with bricks and rubble bedded in lime mortar and overlaid with a lime mortar rendering. But remember that mortar will not bond to a sooty surface and the existing rendering should be well scraped first.

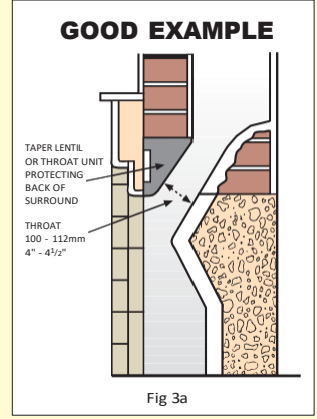

Fig 3a

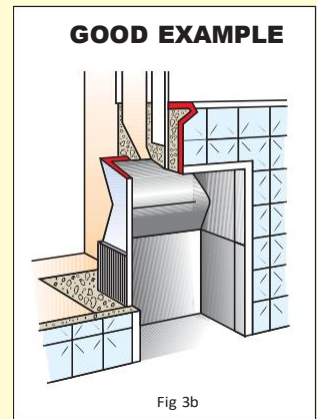

Fig 3b

A.3. FIREPLACE OPENING TOO LARGE

The flow of air and other gases through a flue is limited by the size and constructional details of that flue. All flues have a particular volume carrying capacity or rate of flow according to conditions. If this same amount of gases has to flow through a larger area, such as the fireplace opening, the velocity will be reduced and the result may be that smoke will eddy into the room before it can be drawn up the flue.

Usually an inset open fire with a conventional opening of 550mm x 400mm (22in x 16in) requires a flue of not less than 200mm (8in) diameter, or 185mm (7¹/₂in) square, to clear the smoke and gases. Where the fireplace opening is too large in relation to the flue there is a likelihood of smokiness, particularly if there is a badly formed throat. This trouble is very common with dog-grates or basket grates standing in very large openings.

TEST *There is no simple test for this condition; all that can be done is to check the size of the flue and compare it with the size of opening. If the area of the fireplace opening is more than eight times the area of the flue, there is a likelihood of smokiness. With a short flue as in a bungalow or top floor flat this ratio may need to be reduced to 6 to 1. There are, however, many variable factors and it is difficult to lay down a hard and fast rule.*

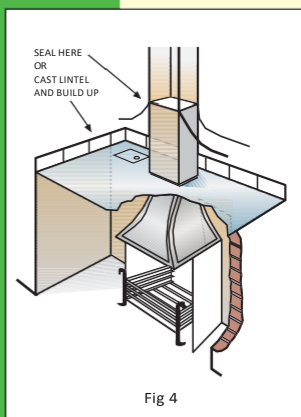

REMEDY

Altering the size of the flue is usually an expensive option, it is often impracticable to reduce the fireplace opening. All that can be done with an inset fire is to consider replacing it with a closed roomheater. If you wish to retain a dog-grate or similar fire in a recess in a period setting, smoking back can often be overcome by fixing a metal register plate across the underside of the top of the recess, and a metal canopy over the fire with its constricted end projecting through the register plate as high as possible to connect if possible to the flue gather see Fig.4.

Better still, however, would be to install a purpose-made free-standing fire which also has an integral throat restrictor. This is enclosed at the back and two sides up to the canopy, so that all the over-fire air for the flue must pass through the fire opening which is properly related in size to a 225mm x 225mm (9in x 9in) or an equivalent 250mm (10in) diameter flue. Such a fire can be positioned in a large recess without smoke-back occurring, providing that the height of the recess is not greater than the outlet end of the canopy and the flue is properly constructed.

A.4. FIREPLACE (SURROUND) OPENING TOO HIGH

Although modern surrounds often have 550 millimetre (22in) high openings (for raised fires), or 500 millimetre (20in) (for hearth-level fires), there are still many open fires with 600 millimetre (24in) openings. The higher the opening, the easier it is for smoke to trickle out into the room before reaching the flue, particularly if there are aggravating circumstances such as cross-currents of air, due perhaps to doors on both sides of the fireplace, or if there is a restricted flow of air into the room.

TEST *Cut a piece of cardboard or similar material a little longer than the width of the opening and about 100 to 150mm (4in to 6in) wide. Place this across the top of the opening so that the latter is reduced in height to 550mm (22in) from the hearth or 500mm for a sunken fire.*

REMEDY

If smoking ceases, a permanent non-combustible canopy or plate securely fixed in the same position is the simplest cure, but see that the throat is also properly constructed.

A.5. FLUE OFFSET TOO LOW, TOO ABRUPT, TOO LONG

Flues are very frequently carried over, or 'offset', to one side or the other of the chimney breast, either to make room for other flues in the same stack or to by-pass the fireplace upstairs. Sometimes this offset is too low, or the bend is too abrupt, or perhaps the traversing length is too long - sometimes all three faults are found in the one offset. The result is poor chimney draught and a smoky fire.

TEST *It is not always an easy matter to follow the 'run' of a flue, and probably the easiest means of checking is with a chimney sweep's rods. These will indicate the height of the first bend and give some idea of the angle of traverse. A long traverse is only possible in a wide chimney breast or in an unusual chimney construction.*

REMEDY There is usually no alternative to opening the front of the chimney breast (or back, if it is on an outside wall) and rebuilding the offending part of the flue. It is such a major operation, however, that all other possible causes of smokiness should be checked first. The essential features of a good offset are shown in Fig.6.

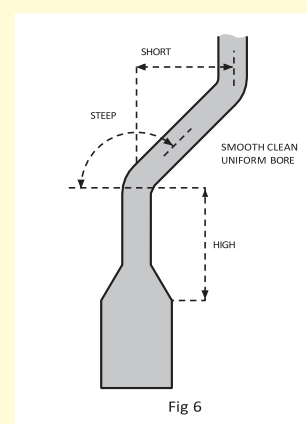

A.6. PARTIAL BLOCKAGE OR CONSTRICTION OF FLUE

This usually occurs at an offset and may be due either to bad workmanship at that point or foreign matter or soot accumulation at the bend. A common cause of trouble is mortar that was dropped down the flue when it was being built and now partially blocks the bend see Fig.7.

TEST *The sweep's brush will often reveal such obstructions, and may sometimes dislodge them if a scraper is fitted to the end of the rods.*

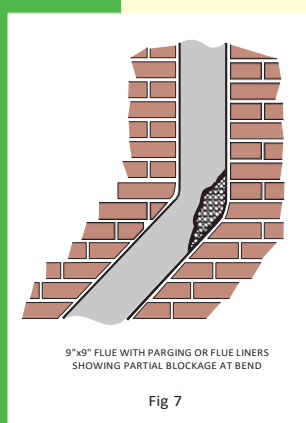

Another method of checking a flue for obstructions is to lower a 'coring ball' on the end of a rope down the flue. The coring ball of concrete or metal, which should be of such a size that it has not more than 25mm (1in) clearance in the flue, will determine the exact position of the blockage if a knot is tied in the rope when the ball gets stopped, and may even dislodge it.

REMEDY If the blockage cannot be removed by other means, the flue at that point will have to be opened for clearing.

A.7. UNSUITABLE SIZE OF FLUE

The conventional 225mm x 225mm (9in x 9in) brick flue, although perhaps not ideal, is generally suitable for all types of domestic appliances, but anything over this size, such as the large flues sometimes found in older houses, may cause smokiness chiefly because such a large flue never really gets warm. On the other hand, flues must not be too small; open fires in general should not have flues smaller than about 200mm (8in) diameter or 185mm (7¹/₂in) square, particularly if housecoal is to be burned, but flues of about 150mm (6in) diameter may well be better for small independent boilers, roomheaters and cookers burning smokeless fuel (175mm or 7in for multifuel appliances).

TEST *Check size of flue.*

REMEDY A very good method of reducing the size of a flue is to have it lined with an insulating lightweight concrete mix achieved by first lowering an inflatable tube down the flue, blowing it up to the appropriate size, and then pumping the insulating concrete around it. This is also a very effective way of re-lining a chimney leaky with age and use, particularly an outside boiler flue suffering the effects of condensation. Chimney lining needs to be done by a specialist firm with an Agrément Certificate but it is a quick and effective remedy causing little disturbance.

Large flues can also be 'lined', or piped, with flue liners of a suitable size and type. Proprietary flue liners of fireclay or refractory cement are normally used, although ceramic or pumice liners could also be used. It is important to insulate the flue by filling between brickwork and liner with a weak mix of vermiculite or Perlite cement. Rebuilding a flue is of course a costly major operation. With an undersize flue it is often possible to change the appliance for a more efficient type.

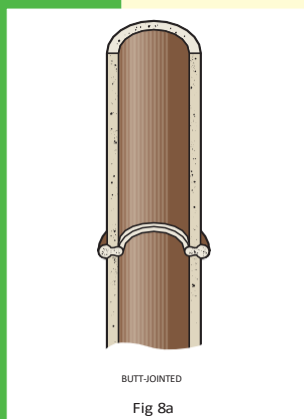

A.8. BAD FIXING OF LINERS

Since the Building Regulations came into force in 1965 clay flue liners with rebated or socketted joints have been used. Some older houses, however, may have liners with plain ends which are butt-jointed. Sometimes these were fitted 'out of line' and overlapped, resulting in a series of obstructive ledges which hinders up-draught see Fig. 8b

Another fault often found with all forms of section liners is a protruding ring of cement at joints which should have been removed during installation see Fig.8a.

In other cases, liners have been installed one on top of another with no jointing between them, and infilling between the liners and the brickwork omitted. This is sufficient to cause a leak at each joint and spoil the draught and such a flue is unsound.

TEST *A scraper on the end of sweeping rods will usually reveal any obstruction. A smoke test as described on page 15 may indicate by visible smoke the extent of leakages. This is best carried out by a builder.*

REMEDY If the trouble is due to cement rings, they can often be removed by careful scraping, but for overlapping joints (which can be checked if necessary by cutting open the brickwork of the chimney), there is no treatment apart from removing the existing lining and relining using one of the methods described in A7.

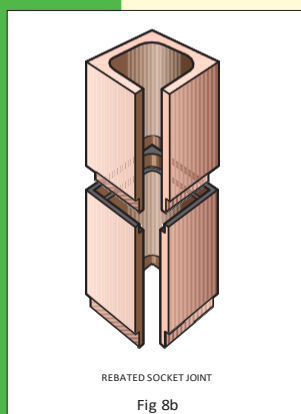

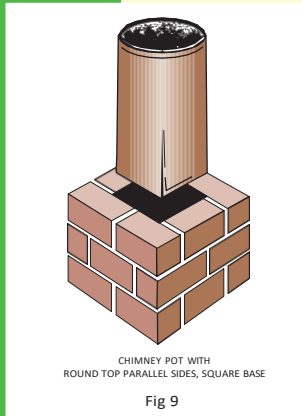

A.9. UNSUITABLE CHIMNEY POT

In a great many cases, round-base chimney pots are fitted to square flues by placing small pieces of tile across the corners of the flue to provide a base for the chimney pot; this results in four obstructive ledges which, although not perhaps the sole cause of the problem, may be the 'last straw' along with other faults. Many chimney pots taper to the outlet in the belief that this improves the draught and reduces the entry of rain and wind. A pot with parallel sides, not tapered, and with a square base Fig.9 offers less resistance to the outward flow of products of combustion and is better for an open fire. This may help to take away the 'last straw'.

TEST *By inspection.*

REMEDY Replace with a square-base pot with parallel not tapered sides Fig.9.

A.10. PARTIALLY BLOCKED CHIMNEY POT

When smoke flows through a flue, the particles of soot are particularly attracted to cold surfaces such as the inside of a chimney pot. Usually most of the soot is removed by the sweep's brush, but if the smoke is high in tar content the deposits may resist everything but a hammer and chisel. In districts where housecoal with a high tar content is commonly used,

chimney pots should be as short as possible (but not less than 150mm) and well protected by steep flaunching; it is also advisable for the pot to have parallel sides see A.9 with an outlet not less than 200mm (8in) diameter or larger if the flue is larger, preferably salt glazed internally.

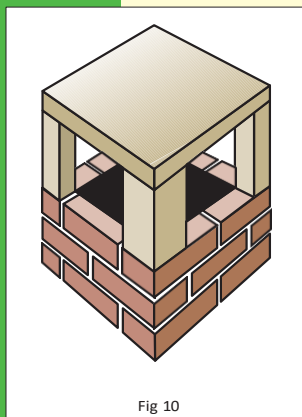

TEST *A sweep's brush usually reveals the obstructions.*

REMEDY If the trouble is recurrent, replace the pot with a shorter one of a larger size, or use smokeless fuel. The 'dovecote' top shown in Fig.10 is sometimes used to protect large flue outlets against wind and rain; it is not, however, intended to replace the recommended square or circular termination, which should be built into the brickwork so that only 50mm (2in) or so projects above the stack. The combined area of the four openings should equal at least twice the area of the flue.

A.11. BAFFLING OF FLUE GASES

Fig.11a, 12a and 13a show fixing faults which often result in poor draught. In each case the flue pipe projects too far into the flue so that the free flow of gases is hindered.

TEST *By inspection.*

REMEDY The type of installation shown in Fig.11a is best treated by the replacement of the register plate with a precast or cast-in-situ concrete lintel as shown in Fig.11b. This enables the flue pipe to be sealed using fibreglass rope that can be caulked into the gap between the flue pipe and the hole in the lintel. The sides of the lintel should be sealed to the fireplace wall from above using mortar. A new flue should be constructed using liners and infill to prevent any voids. A double seal soot door should be fitted to the face of the flue in the position shown to enable a collection chamber to be formed. Where a freestanding roomheater is placed in front of an existing open fire a closure plate must be fitted covering the fire opening and sealed to the fire surround. Infill should be placed behind the register plate up to a height as shown in Fig.12b. The flue pipe from the appliance should be sealed into this closure plate where it passes through. This flue pipe must be short enough to allow a clearance of at least 100mm (4") between the end of the flue pipe and the fireback.

Flue pipes projecting into brick flues should be via bends of 135° to avoid a sharp change in direction of the flue gases, and the pipe should be cut flush with the inner wall of the flue see Fig.13b. To ensure a good seal between the flue pipe and the chimney a wall sleeve must be fitted and the gap between the flue pipe and sleeve caulked with fireproof rope. The soot door should be 'double' (have an inner plate as shown in Fig.14 to avoid excessive cooling of the gases. It should also be slightly below the entry of the flue pipe so that the hot gases do not impinge on it and so that there is a small catchment space to reduce the possibility of the flue pipe becoming blocked by deposits dropping from the flue. There should be no large cavity below the soot door.

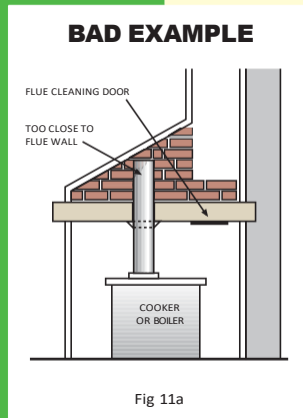

Fig 11a

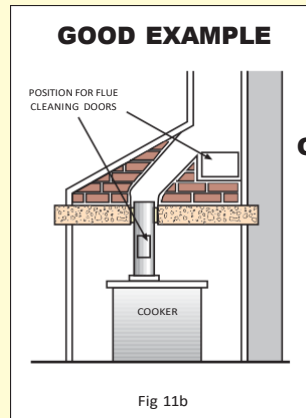

Fig 11b

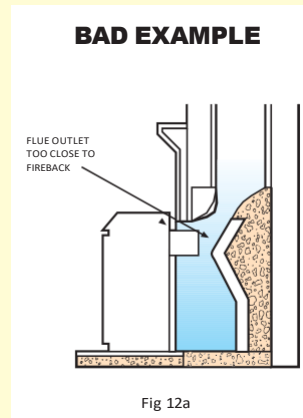

Fig 12a

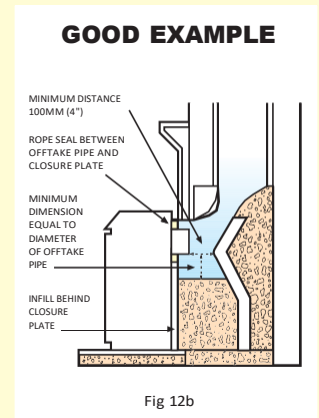

Fig 12b

A.12. AIR LEAKS

Cold air leaking into a flue will naturally cool the gases and reduce draught, and it is most important that flues should be airtight. The more usual points of air leakage are around register plates where they butt against the brickwork; the joints around flue pipes projecting through register plates or brickwork; and the joints of flue pipes and soot doors. It is also possible for a brick chimney to leak air if the brick joints are bad or have cracked, and for air to be drawn from an adjacent disused flue if the brickwork between them (mid-feather or withe) is faulty. In certain conditions this may also result in potentially dangerous outward leakage of fumes.

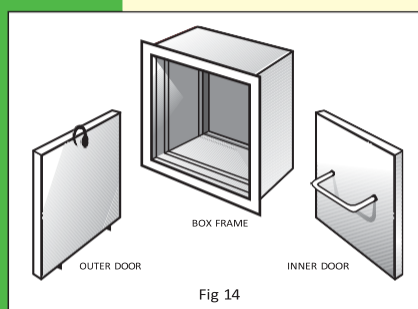

Fig 14

Even flues with modern liners will leak unless they are properly jointed during installation with high alumina cement and the space around them solidly filled in.

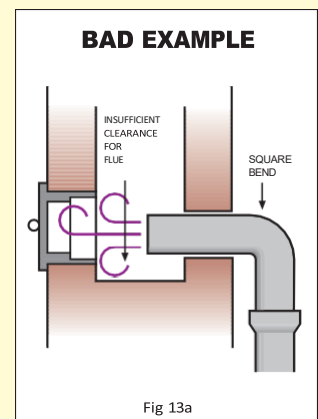

Fig 13a

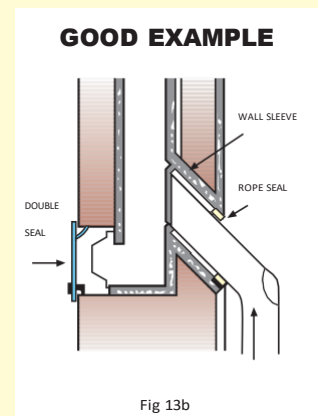

Fig 13b

Symptom B

No

Up-

draught at

all

TEST *Inspection will usually reveal leaky joints, and the flame of a lighted taper or candle held near flue pipe joints, etc., will be drawn in to confirm the leakage. Leakage through the brick work of a chimney is determined by a 'smoke test' see page 15.*

REMEDY All faulty flue pipe joints, etc., should be made good bearing in mind that fire cement is generally hard setting and therefore liable to crack and fall out. There are non-hard setting compounds available specially prepared for flue pipe joints, or alternatively soft heat-resisting rope, string or tape should be used according to the size and type of joint to be sealed. Non-hard setting compound can then be applied if desired as a 'top dressing'. Leakage through brick-work can be remedied by the first re-lining method described in A.7. If leakage appears around a register plate (notoriously difficult to seal) replacing this plate with a cast-in-situ or precast concrete lintel will allow proper seals to be formed.

B.1. COMPLETE BLOCKAGE

If a flue is not kept properly cleaned, soot deposits in time can completely stop draught; the same thing can happen when pieces of chimney pot, slate or brick fall down the flue.

TEST *The sweep's brush will reveal a blockage.*

REMEDY Try the sweep's rods first; if these are unsuccessful, a coring ball lowered from the top may remove the obstruction, but in any case will indicate the exact position for opening the flue. Regular cleaning of the flue is important for safety.

B.2. COLD FLUE

An exposed chimney cools the flue gases rapidly and draught is never as good as it is in a well-protected flue. Moreover, if the fire has been out for some time, or a flue damper or thermostat has been closed for several hours, the chimney draught may well be reduced sufficiently to cause smokiness.

Uninsulated cast-iron or other single wall flue pipes should never be used outside a house as a chimney. The severe chilling of the flue gases, particularly when an appliance is burning slowly, not only results in unsightly condensation but more seriously reduces the flue draught so much that dangerous fumes may be emitted from the appliance, because there is little or no flue draught to carry them away safely up the flue.

TEST

Insert a lighted piece of newspaper in the flue; after a brief delay, the smoke should be carried up the flue.



Symptom C

Chimney

Terminates

in a High

Pressure

Region

REMEDY Give the draught an initial 'boost' by lighting paper at the base of the flue so as to warm the air in the flue. A blow lamp may be used for the purpose. Domestic boiler dampers should always be left in the fully open position, unless very windy conditions make it difficult to control the boiler by its combustion air control.

In the case of a thermostatically controlled appliance an escape of fumes is most noticeable in the morning after the thermostat has been shut for several hours overnight. Giving the boiler a little more work to do by adding a towel rail or small radiator to the gravity system will slightly increase the fluegas temperature. Any uninsulated outside flue pipe must be replaced by a prefabricated chimney system as listed in the HETAS Official Guide to Approved Solid Fuel Products and Services .

C.1. CHIMNEY TOP BEING IN A HIGH-PRESSURE REGION

Fig.15 shows a chimney lower than a nearby object, in this case a roof, and on the windward side of that object. This may be a region of high wind-pressure. There is a low-pressure (suction) on the lee side of the house. It means that air tends to be drawn out of the house on the suction side and tends to be blown in on the pressure side. This can affect the chimney and produce smoke emission by either preventing the up-draught or if the pressure is high enough, causing a down-draught.

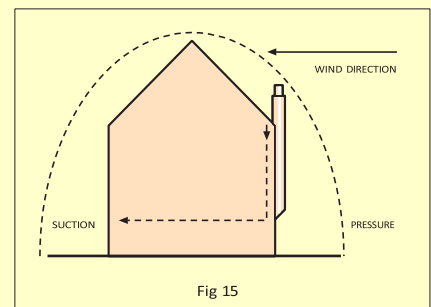

As this condition usually occurs only with the wind in a certain quarter, the situation of the chimney in relation to the roof will indicate the cause of trouble; furthermore, smokiness normally occurs only when there are openings (doors or windows) on the low-pressure side but not on the high-pressure side.

TEST *Open a door or window on the exposed wall; this should equalise the pressures and restore up-draught.*

REMEDY If possible, the chimney should be extended beyond the region of high-pressure; this can be done experimentally in the first place by trying various lengths of sheet metal pipes to determine the extra height needed; in most cases, if it is 0.6 to 1 metre (2-3ft) higher than the ridge or other object responsible for the pressure zone, no trouble occurs.

Unlagged pipes should not be used as permanent extensions, however, as they will chill the flue gases and possibly cause further trouble. The Building Regulations impose a definite limit on unsupported chimney height, and if the permitted extension does not prove sufficient, probably the only alternative is to prevent air being drawn out of the room towards the low-pressure region. This can only be done as a rule by keeping the door closed and seeing that it is reasonably airtight. A suction-inducing cowl is not normally a help unless the top of the cowl is high enough to be out of the pressure area.

Symptom D

Down-

Draught &

Difficult

Site

Conditions

D.1. DOWN-DRAUGHT DUE TO ROOM INLETS (DOORS, WINDOWS, VENTILATORS) BEING IN A LOW-PRESSURE REGION

This trouble occurs mainly with short chimneys (e.g. bungalows and the top one or two storeys of blocks of flats) and with inset open fires. 'Suction' in the room, although normally associated with the condition described in C.1. can sometime cause smokiness regardless of chimney position. Fig.16 shows a condition which in certain circumstances can be difficult to cure. The flow of air around house creates regions of high and low-pressures, which may cause down-draught if that disposition of doors and windows is such that suction exceeds pressure sufficiently to overcome the natural 'pull' of the flue.

TEST Produce sufficient aromatic test smoke in the room to show the movement of air; usually the smoke will drift towards doors and windows in low-pressure regions, thereby indicating that air is being drawn out of the room.

REMEDY As with most other draught troubles, some experimentation is usually necessary. The normal up-draught can be increased by (i) replacing the existing fire with a closed roomheater which reduces air flow very considerably and maintains a higher temperature in the flue gases; (ii) fitting a draught-inducing cowl see Fig.17 to increase up-draught; (iii) fitting a throat restrictor to reduce air flow and increase the temperature in the flue; (iv) draught-proofing doors and windows, etc., which are adjacent to the suction areas.

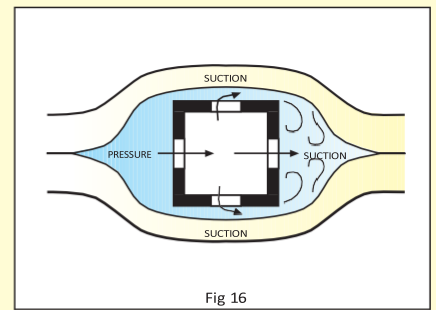

Fig 16

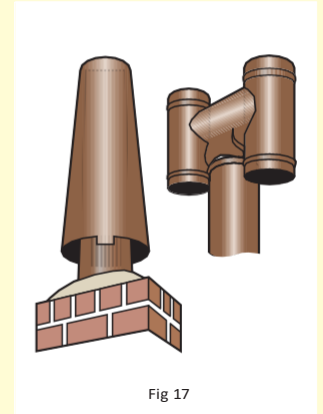

Fig 17

D.2. DOWN DRAUGHT DUE TO WIND CURRENTS

Down-draught due to the wind striking downwards on to the chimney top. Downward striking wind currents often occur in the vicinity of chimney tops when there are higher objects nearby see Fig.18 chimneys on the lee slope of a hill or in a valley may also suffer from this form of down-draught.

TEST Observe the position of the chimney top in relation to other, higher objects such as trees and buildings, or in respect of surrounding land contours. Note whether smoke has difficulty in issuing from the chimney pot and is seen to be blown downwards.

REMEDY If it is impossible to raise the chimney terminal out of the turbulent zone then the simplest remedy is to protect the top of the chimney with a cowl see Fig.17 or dove-cote top see Fig.19.

Sometimes a cluster of chimney pots close together on the same stack may result in smoke and fumes from one flue passing down an adjacent one, particularly where fireplaces are near each other in communicating rooms. Raising the level of termination of one flue by fitting a tall pot is often sufficient to break the syphonage effect. If, however, adjacent flues (often in old houses) are not in use the problem is quickly resolved by capping the unused ones. Do not, however, do this in such a way that the flue cannot be easily opened up if it is likely to be needed later.



Fig 18

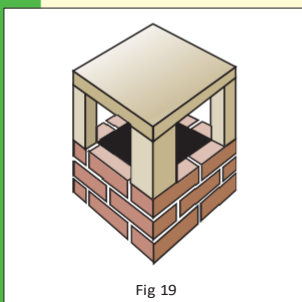

Fig 19

Too Much

Draught

Adequate chimney draught is necessary to induce sufficient air for combustion through the fuel bed and to clear the products of combustion from the appliance up the flue and disperse them to atmosphere.

The amount of draught necessary for this varies with the type of appliance; for independent boilers the makers generally state the desired level of draught at the outlet of the appliance - usually in the region of 1.5 to 2.0mm (.06 to .08in) water gauge. Since most well constructed flues to which a closed appliance is connected produce a higher draught than this, the rate of combustion in a boiler may be higher than is desirable when the air control is open. If this is the case it will often be too strong for the normal air control to check during periods when the boiler is idling, especially in windy conditions. For such circumstances an adjustable draught stabiliser should be fitted reasonably close to the outlet of the boiler and set by use

of a draught gauge to give the optimum draught for the particular appliance. This means that in use the boiler will always operate under a steady 'pull' or draught - and more economically so than under varying and often excessive chimney draught.



Condensation

Water vapour is one of the products of combustion produced when any kind of fuel is burnt. Fuels with a relatively high hydrogen content produce more water vapour than others. As long as the water remains in its vapour state until it leaves the flue, no problems arise, but when the flue gases are cooled below a certain level, moisture will condense on the surfaces of the flue. Unfortunately, condensation often combines with sulphur compounds in the flue gases and with sulphates in brick work to form weak acids which, over a period of time, attack brickwork and mortar joints causing damage to the chimney fabric. In some cases condensation will even penetrate brickwork, staining plaster and interior decorations, particularly in rooms on upper floors. Other contributory causes are flues too large for appliances, burning wet refuse like damping down with tea leaves, and using very wet fuel stored in the open.

The remedy is to line the flue with an appropriately sized acid resistant flue liner which is then insulated around with backfill. This prevents any further condensation from affecting the brickwork, and by reducing the heat loss from the flue reduces the incidence of condensation. The condition is only likely to arise in houses built before 1966. In later houses all flues should be adequately lined with impervious material.

Lining a flue may be done effectively to combat the condensation as described under A.7. Only certain flexible stainless steel liners are suitable for use with solid fuel appliances. For further details see the HETAS Official Guide to Approved Solid Fuel Products and Services.

Smoke

Test

Method

SUGGESTED METHOD FOR CHECKING THE SOUNDNESS OF A CHIMNEY BY SMOKE TEST.

- The appliance should not be alight.
- Arrange for access into the roof space and to other parts of the house through which the chimney flue runs, and to the top of the chimney stack.
- Where a chimney stack is shared by two or more houses or flats, if possible make sure that no other appliances connected to the stack will be in use during the test. Note: If there is leakage through a mid-feather (with), ie the wall between flues, it may not be possible to detect this if another appliance is in use.
- Warm the flue by burning some paper at the bottom of it.
- Have available suitable means to seal off temporarily the top and bottom of the flue after it has been filled with smoke (A plastic bag and sealing tape is useful for 'capping' the chimney pot).
- Light a smoke cartridge or pellets in the bottom of the flue.
- As soon as smoke issues from the chimney pot immediately seal off top and bottom of the flue, leaving the smoke cartridge to burn out and fill the flue with smoke.
- Observe all parts of the chimney for smoke leakage.
- Observe whether smoke issues from the top or bottom of any other flue in the same stack.
- Any smoke test should continue for at least 10 minutes.

**Appliance installations should always be carried out by a qualified installer.
This leaflet is for guidance only and should only be used for reference purposes.**

Always buy solid fuel from an Approved Coal Merchant

Our team of specialists are always available to give advice on all aspects of solid fuel heating including installation, maintenance and spare parts. Other guides are available on request.

Phone 01773 835400 for details

www.coalmerchants.co.uk

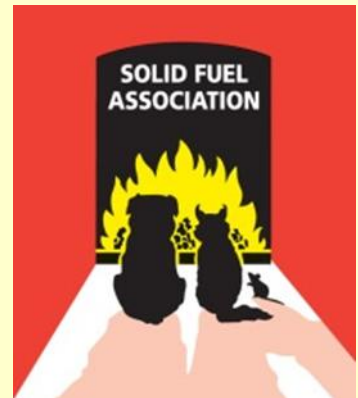

www.solidfuel.co.uk

Solid Fuel Association
95 High Street
Clay Cross
Chesterfield
Derbyshire
S45 9DZ
01773 835400
e-mail: sfa@solidfuel.co.uk

Updated by JLP 7th April 2026